

White-Rodgers™

Pactrol - P25'F', P25'F'HSi, P25'F'EXT

The Most Complete Family of Full Sequence Gas Ignition Controls.

Fully certified to EN298 – 2012.

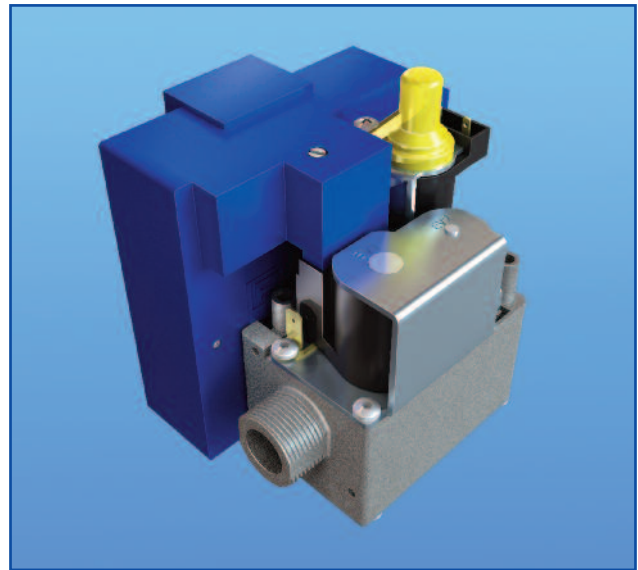
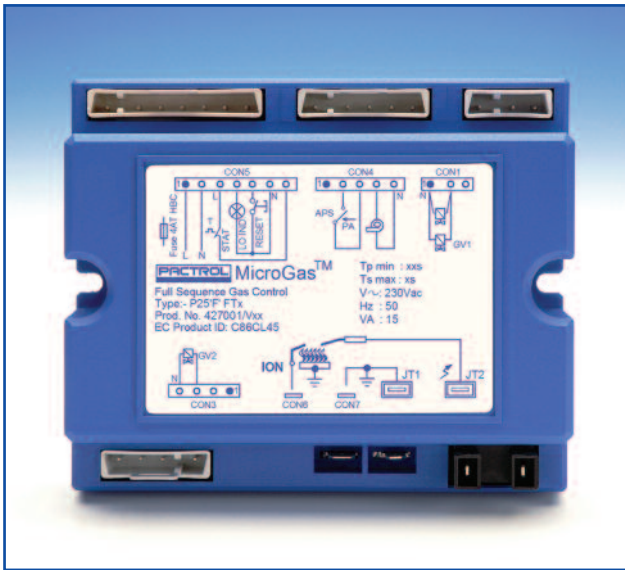

Typical applications

- Heating boilers
- Water heaters
- Warm air heater
- Radiant tube heaters
- Catering appliances
- Leisure appliances

Key features

- Voltage 230Vac.
- Atmospheric or Fanned applications.
- P25'F' has integral spark ignition. Any configuration for spark ignition and flame detection.
- P25'F' HSi – Hot Surface Ignition suitable for either White-Rodgers Silicon Nitride HSI element (dual probe only) or with single HSI incorporating flame sensing. This option uses an external transformer and Crystal Technica element.
- P25'F' EXT has a switched live output which may be connected to an external ignition source.
- Volatile or Non Volatile lockout.
- Robust design with reliable operation in all environments.
- Molex or Stelvio / Stocko connections.
- Wide range of options and timings.
- Can be mounted onto the new White Rodgers range of gas valves using the CVC housing.

Design

This family of controls offers safe start up and supervision of a wide range of gas burner applications in all markets. By a combination of hardware and software selection, customers can control fanned or atmospheric sequences, volatile or non volatile lockout, plus many timing and logic functions.

- Supply voltage 230V~
- Supply frequency 50/ 60Hz
- Phase relationship Phase - Earth bonded / Non Phase -
- Internal fuse 4 AT HBC
- Power consumption < 5W

- Lock-out type Programmable: volatile or non volatile lock-out
- Lock-out reset response time Programmable
- Lock-out reset input Momentary switch contacts

- Flame detection principle Flame Ionisation rectification
- Electrode configuration Single, Dual or triple probe (depending upon model type)
- Flame sensitivity Programmable
- Flame Detector response time Flame on: 1 s max.
Flame off: Programmable
- Maximum detection lead length 5 Metres
- Air proving 2 terminal APS or none

Maximum Loads at 0.6pf @ 230V~ (where applicable):

- Lock-out indicator 1 A
- HSI/External Igniter 2 A (3 A peak current)
- Fan 2 A (cont) 4 A (peak)
- Gas Valve 1 1 A
- Gas valve 2 1 A
- Total maximum load 4A**

P25'F' Integral spark ignition:

- HT Open circuit voltage >15kV minimum @ 30pF load
- Spark gap 2.5 – 4.5 mm
- Spark rate 50, 25, 16.7, 12.5, 10, 5, or 1 Spk/Sec @ 50Hz mains
60, 30, 20, 15, 10, 3, or 1 Spk/Sec @ 60Hz mains

Maximum HT lead length 0.5 metre

(Resistive suppression cable or 1k Ω wire wound Resistor in HT cable recommended)

Operating Environment

- Protection degree IP20 other ratings upon request
 - Ambient temperature range -10°C to +60°C
 - Humidity 90% max. @ 40° C (non-condensing)
 - Mounting position Not critical
- (HT terminals must be > 15mm away from metalwork)
- Connectors Molex or Stelvio / Stocko

The P25 'F' is available with several factory selectable options:-

- Burner Type
 - A = Atmospheric
 - F = Fanned
- Valve Configuration
 - M = Single Stage main burner ignition (gas valve connected to CON1)
 - T = Pilot + Main burner (both gas valves connected to CON1)
 - Tx1 = Pilot + Main burner (pilot connected to CON1, main connected to CON3)
- Lockout Type
 - L = Non Volatile lockout (indication and reset are connected to CON5)
 - V = Volatile lockout

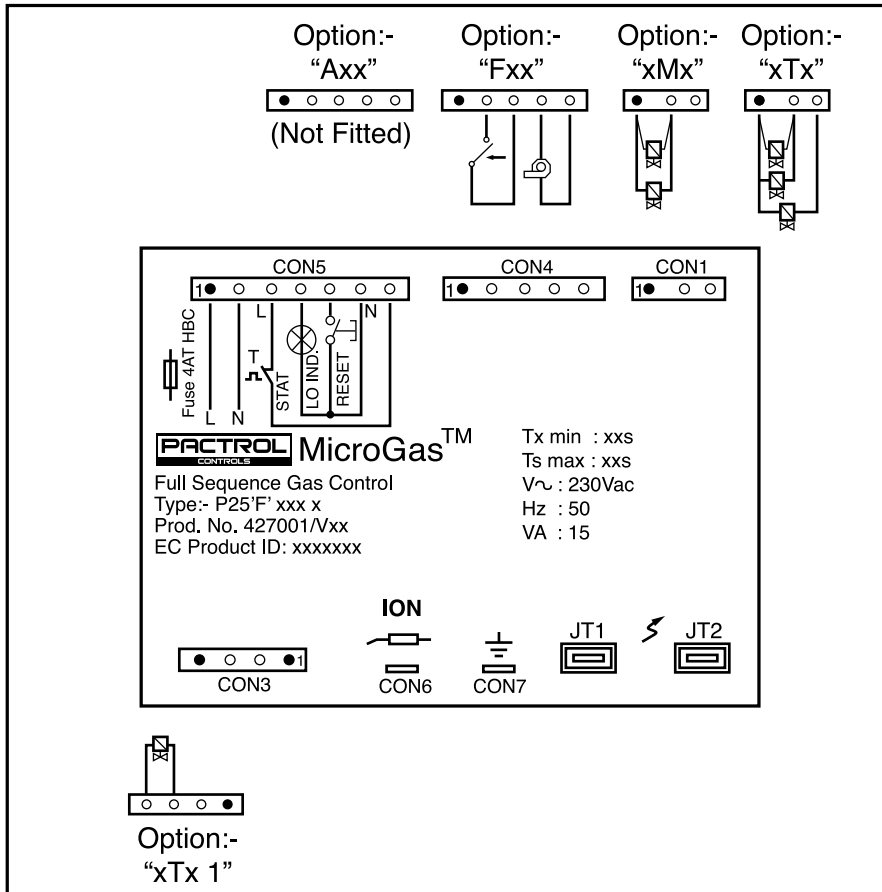

The P25'F' HSi and EXT can be specified as:-

* Burner Type

A = Atmospheric

F = Fanned

* Valve Configuration

M = Single Stage main burner ignition (gas valve connected to CON3)

* Lockout Type

L = Non Volatile lockout (indication and reset are connected to CON5)

V = Volatile lockout

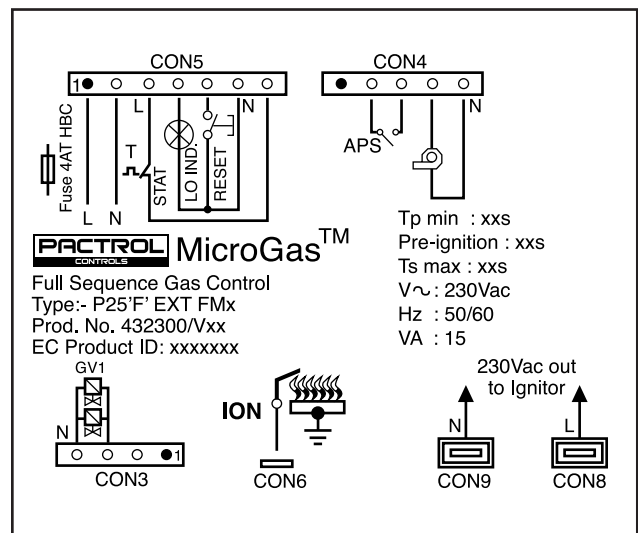
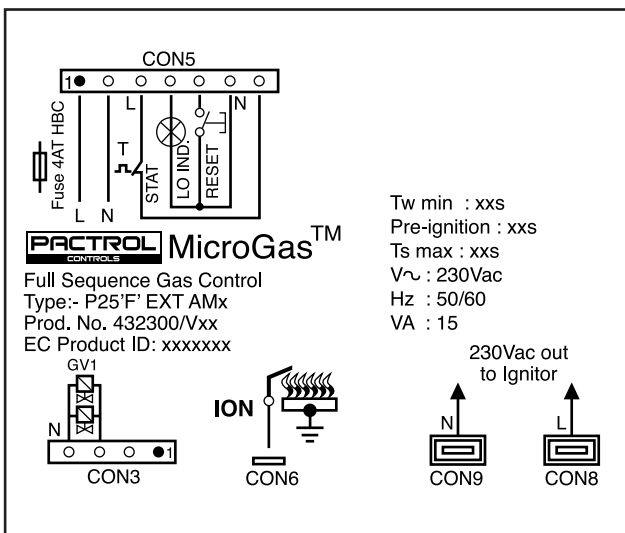
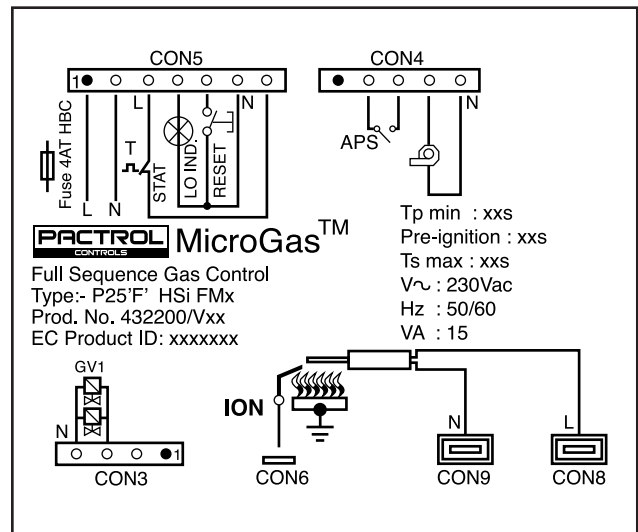
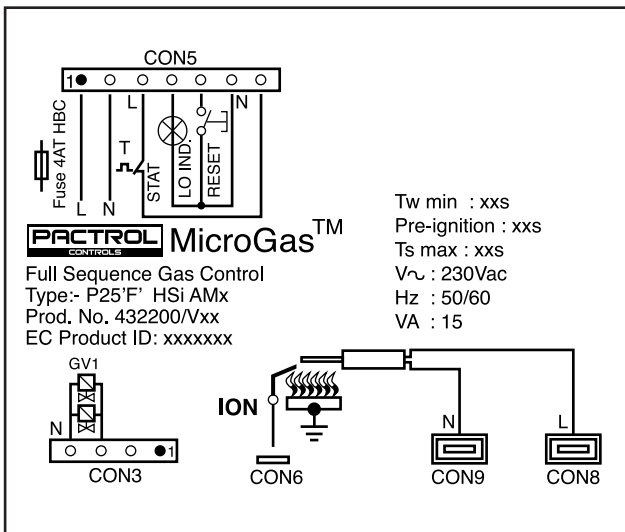

- **Waiting time (T_w):**
For burners without fans, this is the interval between the start signal being given and the energisation of the ignition device/gas valve. During this time, natural ventilation of the combustion chamber and the flue passages may take place.
- **Pre-purge time (T_p) :**
The pre-purge is the time in a fanned appliance, where the purging of flue / air mixture or products of combustion takes place, between the start signal and the energisation of the ignition device. Note T_p only commences after air flow is proved (where an APS is fitted).
- **Pre-ignition time (T_{pi}):**
The pre-ignition time is the time from when the ignition device is energised prior to the energisation of the gas valve.
- **Safety time (T_s) / First safety time (T_{s1})**
The first safety time is the interval between the pilot gas valve, the start gas valve or main gas valve, as applicable, being energised and the pilot gas valve, start gas valve or main gas valve, as applicable, being de-energised if the flame detector signals the absence of a flame. Where there is no second safety time this is also known as Safety Time (T_s).
- **Ignition time (T_i)**
The ignition time is the time the ignition device is energised during the safety period.
- **Pilot Proving time (T_i) (P25F only)**
The time between the end of the first safety time and the start of the second safety time, this time is used to prove the stability of the pilot flame.
- **Second Safety time (T_{s2}): (P25F only)**
Where there is a first safety time applicable to either a pilot or start gas flame only, the second safety time is the interval between the main gas valve (GV2) being energized and both gas valves being de-energized if no main flame signal is present.
- **Flame failure response time (FRRT):**
This is the time between taken to switch off the gas valve(s) following loss of flame. Alternatively it is the time before the restoration of the ignition device if the control is programmed to re-ignite on flame loss.
- **Inter-waiting time (T_{iw}) / Inter-purge time (T_{ip}):**
For systems with more than one ignition attempt this is the delay between one unsuccessful ignition attempt and the next. It is also the purge time for recycling upon loss of flame.
- **Post-purge time (T_{pp}):**
The time that the fan remains energised at the end of the sequence.
- **APS fail time:**
The time allowed for the APS to signal 'air flow' after the fan is started before the control shuts down and turns the fan off. The control will then either go to Lock-out or wait for the APS retry time before attempting to start the sequence again.

- APS retry time:
If the control is programmed to retry on APS failure, this is the length of time fan is switched off before a new restart attempt is made.
- APS dropout time:
The time during which the APS, once proved, is allowed to move to the 'no air' position before an APS fault is generated.
- Lockout - Volatile / Non-volatile
Volatile Lock-out is a safety condition such that a restart can only be accomplished, either by an interruption of the main power and its subsequent restoration or the manual reset of the system.

Non-Volatile Lock-out is a safety condition of the system, such that a restart can only be accomplished by a manual reset of the system.

- Air proving - None / APS fitted
If the burner is atmospheric then the control can be programmed so that no Air Pressure Switch (APS) is required.
If the burner uses a combustion fan with air proving then the control can be programmed to require the use of an APS.
- APS failure Responses - Lock-out on failure / Shutdown with retry
The control can be configured to Lock-out if the APS fails during burning or to shutdown the burner and fan followed by an automatic restart after the APS retry time.
- Fan state in Lockout - On / Off
This parameter allows the fan to be programmed to run indefinitely whilst the control is in lockout, or to shutdown after running for the post-purge time.
- Number of ignition attempts 1 - 5
The number of unsuccessful ignition attempts in a single demand cycle before the control will lockout.
- Reaction to flame loss:
 - I. Lock-out
The control will lockout immediately.
 - II. Re-cycle
Upon loss of flame the control will perform Inter-Purge. Following which the first of its full number of programmed of ignition attempts will occur.
 - III. Ignition restoration
Upon loss of flame the control will initiate a re-ignition attempt within 1 second without closing the gas valve. The control can be programmed for this to be a single ignition attempt or the first of the full number of programmed ignition attempts.
- Phase Sensitivity
The control can be configured to be phase or non-phase sensitive. however there must be a phase-earth relationship in order for the flame detector to function. i.e. there must be a bond between one of the phases.

Pactrol Controls can usually offer a current variant to suit your needs. If needed, we can organise new variants and offer validation on your appliance.

Mechanical Details

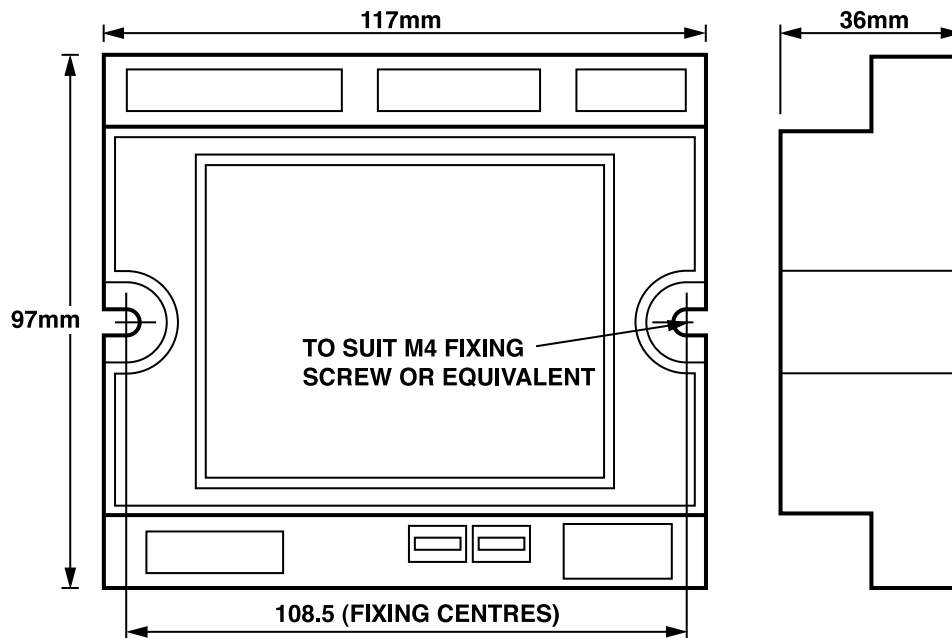

Control housing

The control is mounted in a high impact, flame retardant plastic enclosure. The housing can either be in a discrete housing with two fixing points or supplied in a CVC housing for direct mounting onto the range of WR European gas valves.

Hot Surface Igniters (HSI)

The P25'F' Hsi can drive a nitride HSI. This can be supplied either with external flame detection or we can offer a system from Crystal Technica using external transformers where the HSI element can also be used to sense the flame. This is useful for catering and agricultural applications.

Electrodes and Cabling

Pactrol can also supply a wide range of high performance electrodes and wiring harnesses to suit each application.

Image of HSI (both types) Image of electrode and spark plug cable.

This information may be modified at any time.

Issue 1 - 23/02/16

Pactrol Controls Limited
(A White Rogers company)

Unit 3 Antler Court, Wigan, WN4 8DU, United Kingdom

Tel: +44 (0) 1942 529250 Fax: +44 (0) 1942 529251
Email: sales@pactrol.com www.pactrol.com



Registered in England and Wales No. 00949364

